

Overview

EST3 Power supplies consist of two assemblies, a high efficiency switch mode power supply card and a power supply monitor module. The monitor module mounts to the local rail and distributes the power from its supply to the local rail. The local rail distributes power from all power supplies to other local rail modules and user interface cards resulting in "Shared Power" throughout the system. By paralleling the power supplies on a rail maximum utilization of available power is possible, resulting in fewer power supplies. Up to four power supplies combine in a single enclosure providing up to 28 amps of available power. Battery backup is provided using from one to four sets of batteries, depending on standby power requirements.

Power supplies mount to the back of the chassis units or wallboxes. The associated power supply monitor module mounts on the local rail providing system power distribution and mounting space for any control display module. Access to auxiliary power is via easily accessible terminal blocks located on the power supply monitor module. Each power supply produces 7 Amps of filtered and regulated power. With four power supplies located in an enclosure (one primary and three booster power supplies) 28 amps of current is available for local rail modules, control display modules and the eight auxiliary 3.5 amp power outputs (two per supply).

Standard Features

- High efficiency switch mode
- Increased power distribution efficiency
- power supplies parallel allowing up to 28 amps in a single node
- 120 or 230 Vac operation
- 7 AMP filtered and regulated
- Two 3.5 AMP outputs
- Temperature compensated, dual rated battery charger
- Electronic power limiting
- Automatic load testing of batteries

EST3 Power Supplies

3-PPS/M series, 3-BPS/M series,
3-BBC/M series

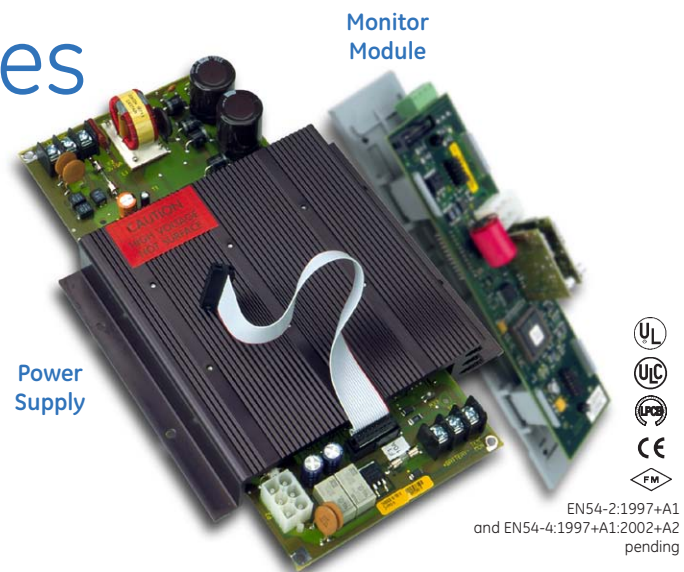

Application

The primary power supply provides the system with battery charging and voltage regulation. Software configures the charger to either 10-24 AH batteries or 30-65 AH batteries and controls the high/low charge rates. Batteries mounted in the same enclosure as the power supply, have their charge rate monitored and adjusted based on the local enclosure temperature, keeping charging rates within battery specification. For remote batteries a temperature probe is monitored in the remote battery cabinet and charge rates are adjusted automatically. Battery damage is unlikely to occur when environmental short term conditions are outside of normal operating ranges.

The EST3 power supplies automatically load test batteries by shutting down the battery charger and placing a load across the battery. If the battery voltage is outside the specification range the power supply reports a trouble. The trouble clears if the battery is able to recover and pass future load tests.

Battery leads are electronically short circuit protected. If a short occurs in the battery leads the charger automatically disables itself and causes a trouble. The system will constantly look to see if the short has cleared. If the short clears the system automatically restores.

During operation on standby batteries, battery voltage is constantly monitored. A trouble is reported if the battery voltage falls below a specified value.

EST3 power supplies provide specific information back to the 3-CPU(1) designed to help speed trouble shooting of system functions. Should a power supply detect a fault, specific diagnostic codes are available to speed trouble shooting. The 3-LCD will display the power supplies address, a specific trouble code, and a text message describing the specific trouble. Text messages are easy to understand and include items like: Battery Trouble, Aux Power Overload Circuit 1, Aux Power Overload Circuit 2.

Power Supply Rules

1. Each battery set needs one charger, either a 3-PPS/M or a 3-BBC/M.
2. Each power supply must be connected to a battery set using an identical length and gauge of wire to keep voltage drops identical.
3. Distribute power supplies and loads evenly across rails.
4. **All battery sets for a panel must be the same capacity (AH), same manufacturer, and same manufacturing date code.**

The Table below illustrates the combinations of power supplies and batteries that meet all the power supply rules.

24 VDC Power Supply Output Current

	7A	14A		21A		28A	
Battery Requirements	One Set, 65 AH max	One Set, 65 AH max	Two Identical Sets, 65 AH max	One Set, 65 AH max	Three Identical Sets, 65 AH max	One Set, 65 AH max	Four Identical Sets, 65 AH max
Required Modules	1 3-PPS/M	1 3-PPS/M 1 3-BPS/M	1 3-PPS/M 1 3-BBC/M	1 3-PPS/M 2 3-BPS/M	1 3-PPS/M 2 3-BBC/M	1 3-PPS/M 3 3-BPS/M	1 3-PPS/M 3 3-BBC/M

Engineering Specification

The fire alarm power supplies must be capable of being paralleled and to load share. Multiple power supplies must be capable of being backed up with a single 24 volt battery set. Each power supply shall be capable of charging up to 65 AH batteries. The power supply must be able to perform an automatic load test of batteries and return a trouble if the batteries fall outside a predetermined range. Power supplies must incorporate the ability to adjust the charge rate of batteries based on ambient temperatures. It shall be possible to adjust for ambient temperature changes in local cabinets as well as remote cabinets.

Installation and Mounting

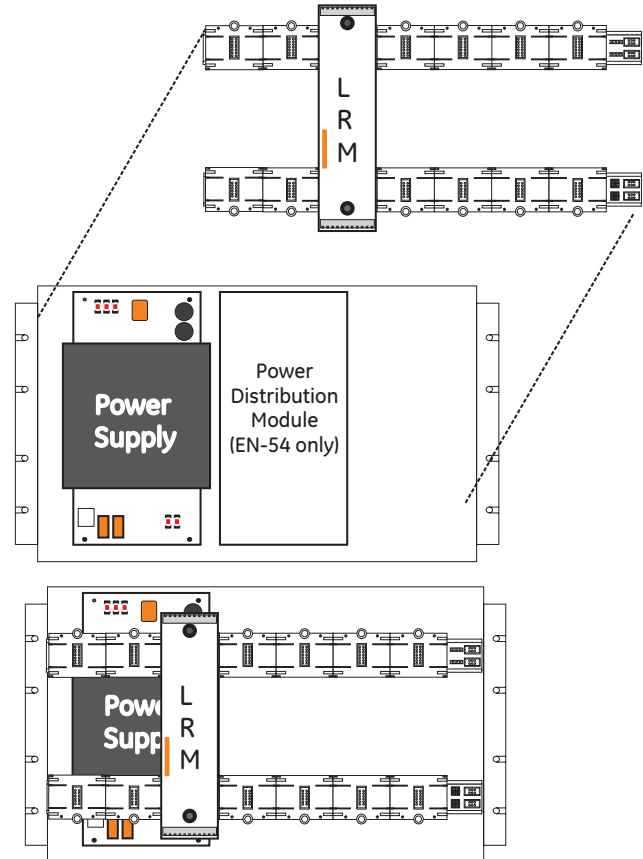

Typical Wiring

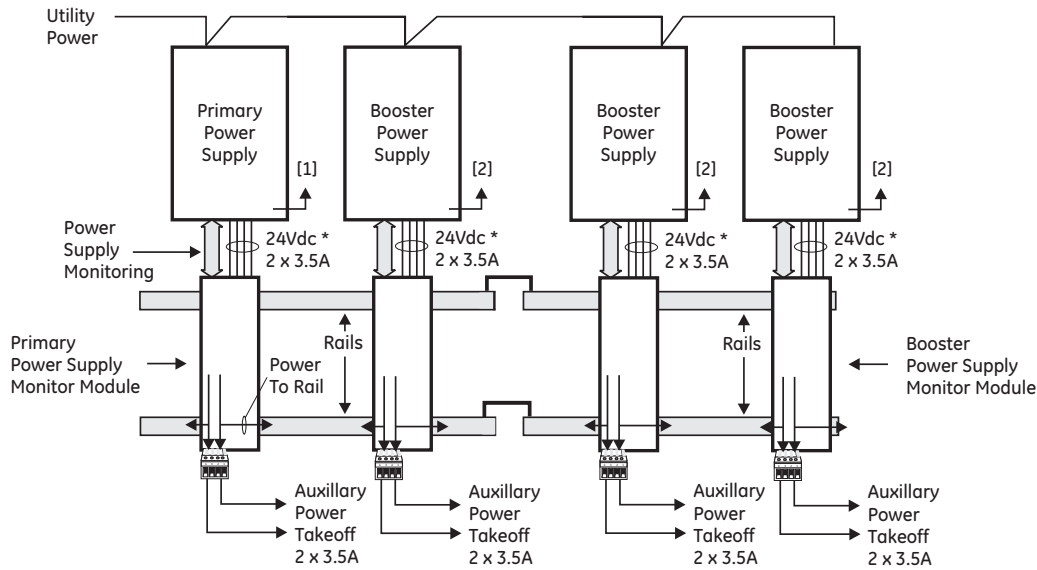

[1] From battery temperature probe terminals.

[2] From battery and from temperature probe terminals if 3-BTSEN-E used.

* Nominal Voltage

Specifications

Catalog Number	3-PPS/M & 3-BBC/M	3-BPS/M	3-PPS/M-230 & 3-BBC/M-230	3-BPS/M-230	3-PPS/M-230-E & 3-BBC/M-230-E	3-BPS/M-230-E
Agency Approvals	UL, ULC, FM	U L, ULC	UL, ULC	UL, ULC	LPCB EN54*, CE	EN54*
Input Voltage	120 Vac, 50-60 Hz	120VAC, 50-60 Hz	230 Vac, 50-60 Hz	230VAC, 50-60 Hz	230 Vac, 50Hz	230VAC, 50Hz
Brownout Level	< or = 102 Vac	96VAC	< or = 195 Vac	184VAC	< or = 195 Vac	188VAC
Input Current	2.0A	2.0A	1.0A	1.0A	1.0A	2.0A
Total Output Current	7.0 Amps	7.0 Amps	7.0 Amps	7.0 Amps	7.0 Amps	7.0 Amps
Battery Charging Capacity	65AH Sealed Lead-Acid	None	65AH Sealed Lead-Acid	None	30AH Sealed Lead-Acid	None
Low Battery Trouble	24 Vdc			22.5 Vdc		
Deep Discharge Cutoff	19.5 Vdc			20.0 Vdc		
Mounting Requirements	1 LRM space, 1 chassis footprint				1 LRM Space + 3-PPS: 2 footprints 3-BBC: 1 footprint	1 LRM space, 1 chassis footprint
Output Voltage	24 Vdc Nominal					
Auxiliary Output Current	Two sources of 3.5Amps each taken from total output current					
Auxiliary Output Terminal Capacity	18 AWG to 12 AWG (1mm ² to 2.5 mm ²)					
Output Protection	Electronic power limiting & heat sink temperature					
Ground Fault Detection	10K Ohm					

*EN54-2:1997+A1 and EN54-4:1997+A1:2002+A2 pending

U.S.
T 888-378-2329
F 866-503-3996

Canada
T 519 376 2430
F 519 376 7258

Asia
T 852 2907 8108
F 852 2142 5063

Australia
T 61 3 9259 4700
F 61 3 9259 4799

Europe
T 32 2 725 11 20
F 32 2 721 86 13

Latin America
T 305 593 4301
F 305 593 4300

www.gesecurity.com

© 2006 General Electric Company
All Rights Reserved

Ordering Information

Catalog Number	Description	Ship Wt., lb. (kg)
3-PPS/M	Primary Power Supply w/ local rail module 120V 50/60 Hz	5 (2.3)
3-BPS/M	Booster Power Supply w/ local rail module 120V 50/60 Hz	5 (2.3)
3-PPS/M-230	Primary Power Supply w/ local rail module 230V 50/60 Hz	5 (2.3)
3-BPS/M-230	Booster Power Supply w/ local rail module 230V 50/60 Hz	5 (2.3)
3-PPS/ M-230-E	Primary Power Supply w/local rail module 230V 50 Hz, EN54* Certified, CE	5 (2.3)
3-BPS/ M-230-E	Booster Power Supply w/local rail module 230V 50 Hz, EN54* Certified, CE	5 (2.3)
3-BBC/M	Booster/Charger Supply w/local rail module 120V 50/60Hz	5 (2.3)
3-BBC/M-230	Booster/Charger Supply w/local rail module 230V 50/60Hz	5 (2.3)
3-BBC/ M-230-E	Booster/Charger Supply w/local rail module, 230V 50/60Hz, EN54* Certified, CE	5 (2.3)
3-BBCMON(-E)	Booster/Charger Monitor Module with charger capability (upgrade 3-BPS/M(-230)(-E) to 3-BBC/M-(230)(-E))	5 (2.3)
3-BTSEN	Distribution Module required when battery installed in remote cabinet	.5 (.22)
3-BTSEN-E	Distribution and Temperature Sensor Module. Required in EN54* Markets when battery installed in a remote cabinet.	.5 (.22)

*EN54-2:1997+A1 and EN54-4:1997+A1:2002+A2 pending



imagination at work